

V-TORK®



VTH Series Declutchable Manual Gear Override



High performance and high reliability
Fully compliant with the latest international standards and regulations
More applicable to a wide range of specifications and higher cost performance
Compact design is better suited for a variety of industrial applications



Design

VTH series declutchable gear override adopts new type of worm gear and vortex rod drive mechanism, integrating the latest technology and material of declutchable gear override, based on extensive experience of field installation and product application, mainly dedicated to opening 90° stroke switch valves such as ball valve, plug valve, butterfly valve, and assisting pneumatic and electric actuators to guarantee opening and closing safely. It has been fully approved by practice the series features following advantages:

- ☆ High performance and high reliability
- ☆ Fully compliant with the latest international standards and regulations
- ☆ More applicable to a wide range of specifications and higher cost performance
- ☆ Compact design is better suited for a variety of industrial applications

Structure

1. Integrate and compact design which is rational with miniature size, light weight, large output torque and labor saving.

2. The connecting flange and connecting shaft diameter on the top and the bottom are conform to the latest international standard ISO5211 which is a convenient interface with valve and actuator presenting superior interchangeability for installation and replacement.

3. The self-locking design of worm gear contributes to the strengths like convenience, security and reliability in operation process.

4. Dual independent travel stoppers can conveniently and precisely implement $\pm 10^\circ$ adjustments externally in two directions, allowing the series in alignment with valve on both the opening and closing phases of the stroke.

5. The series are specially factory lubricated with regard to the worm gear to improve the operational reliability, lubricity and service life.

6. The integrate anti-off design of the output shaft highly prioritized security. The fracture resistance and service life are optimized for nickel plating treatment.

7. Superior performance of dust-proof and water-proof due to sealing rings applied at the interface between upper and lower housings as well as the interface between output shaft and housing to guarantee the leakproofness, dust-proof and water-proof of the series.

8. Corrosion resistance technology is adopted with respect to the interior and exterior housing at the top and the bottom. Fine ground shaft hole surface lead to low friction coefficient and high cycle life.

9. The series realizes free switch between manual and pneumatic operation that lift the limit pin and rotate the handle to lower right to automatic limit position to achieve automatic operation, and achieve manual operation conversely.

10. Surface treatment is optional with paint spraying or epoxy resin with different color options as per customers' requirements.

11. Working temperature:
 low temperature type: $-40^\circ\text{C} \sim 80^\circ\text{C}$
 standard temperature type: $-20^\circ\text{C} \sim 80^\circ\text{C}$
 high temperature type: $-15^\circ\text{C} \sim 150^\circ\text{C}$

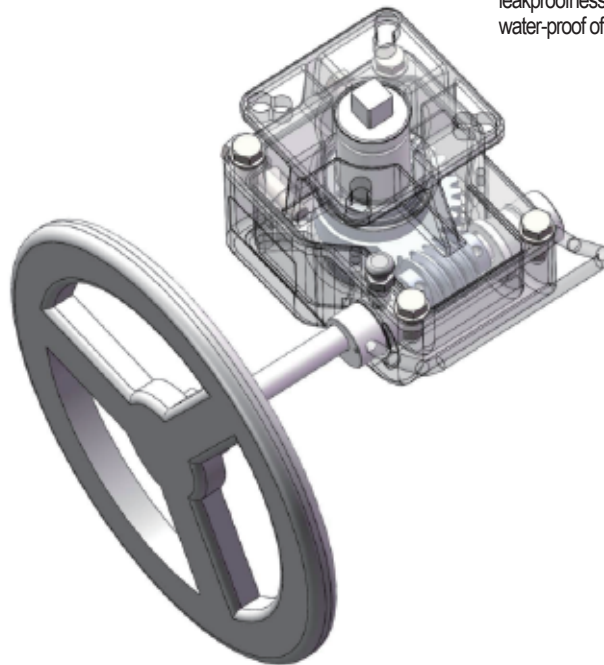

Product Selection Range, Accessories and Quality Management

Selection Range :

- A. The series in all specifications are supplied with 304 or 316 stainless steel output shafts as requested.
- B. For applications under extremely high and low temperature, all models are supplied with corresponding FPM or silicone rubber O-ring with special lubricant.
- C. The female pinion drive is standard with double square and diagonal square output drive at the bottom, and optional with keyed drive, flat head drive. And customized design as per customers' specific requirements is also available.

Quality Management:

- VTH series declutchable manual gear override production process is fully compliant with ISO9001.
- 100% of all units are factory tested and externally marked with dedicated serial number for traceability.
- 100% of all units are individually boxed with suitable cardboard carton for protection and appropriately labeled in detail for identification.

Optional Accessories:

- Bracket
- Connector
- Solenoid Valve
- Limit Switch
- Proximity Sensor
- Pneumatic Actuator
- Positioner
- Complete set of square output shaft sleeves in reduced sizes

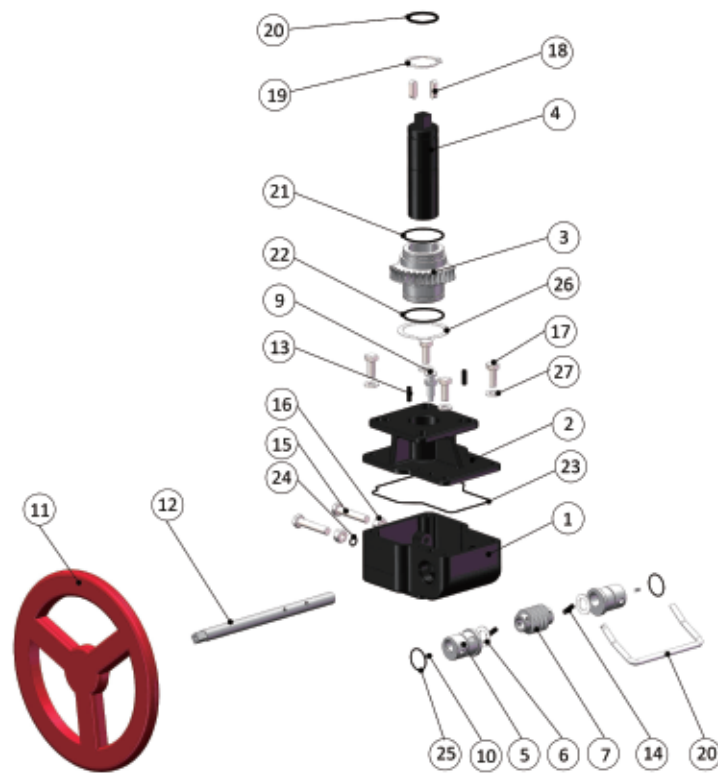

Item No.	Part Name	Material	Qty.	Item No.	Part Name	Material	Qty.	Item No.	Part Name	Material	Qty.
1	Body	Aluminum Alloy	1	12	Scroll Shaft	Nickel Plated Carbon Steel	1	23	O-ring (Adjustment)	NBR	2
2	Bracket Cap	Aluminum Alloy	1	13	Cylindrical Pin	Alloy Steel	2	24	O-ring (Eccentric Sets)	NBR	2
3	Worm Gear	Ductile Iron	1	14	Cylindrical Pin	Alloy Steel	2	25	Flat Washer	Stainless Steel	1
4	Worm Shaft	Nickel Plated Carbon Steel	1	15	Adjustment Bolts	Stainless Steel	2	26	Flat Washer	Stainless Steel	4
5	Eccentric Sets	Nickel Plated Carbon Steel	2	16	Nuts	Stainless Steel	2	27	Flat Washer	Stainless Steel	1
6	Bearing Components	Component	1	17	Bolts	Stainless Steel	4				
7	Vortex Rod	Carbon Steel	1	18	Flat Key	Carbon Steel	2				
8	Handle	Nickel Plated Carbon Steel	1	19	Retaining Ring	Spring Steel	1				
9	Limit Assembly	Component	1	20	O-ring (Worm Shaft)	NBR	1				
10	Set Screws	Stainless Steel	2	21	O-ring (Worm Gear)	NBR	2				
11	Hand Wheel	Carbon Steel	1	22	O-ring (Top Cap)	NBR	1				

Technical Data (Metric Unit)

Model	Velocity Ratio	Input Torque (N.m)	Output Torque (N.m)	Override Diameter (mm)	Weight (Kg)
V TH-S1	26:1	50	100	Φ 180	2.8
V TH-S2	30:1	60	215	Φ 200	4.2
V TH-S3	38:1	90	434	Φ 280	6.8
V TH-S4	54:1	110	1000	Φ 300	13.5
V TH-S5	80:1	140	2000	Φ 400	22
V TH-S6	78:1	200	3500	Φ 500	30
V TH-S7	98:1	200	4200	Φ 600	38

Sample Reference

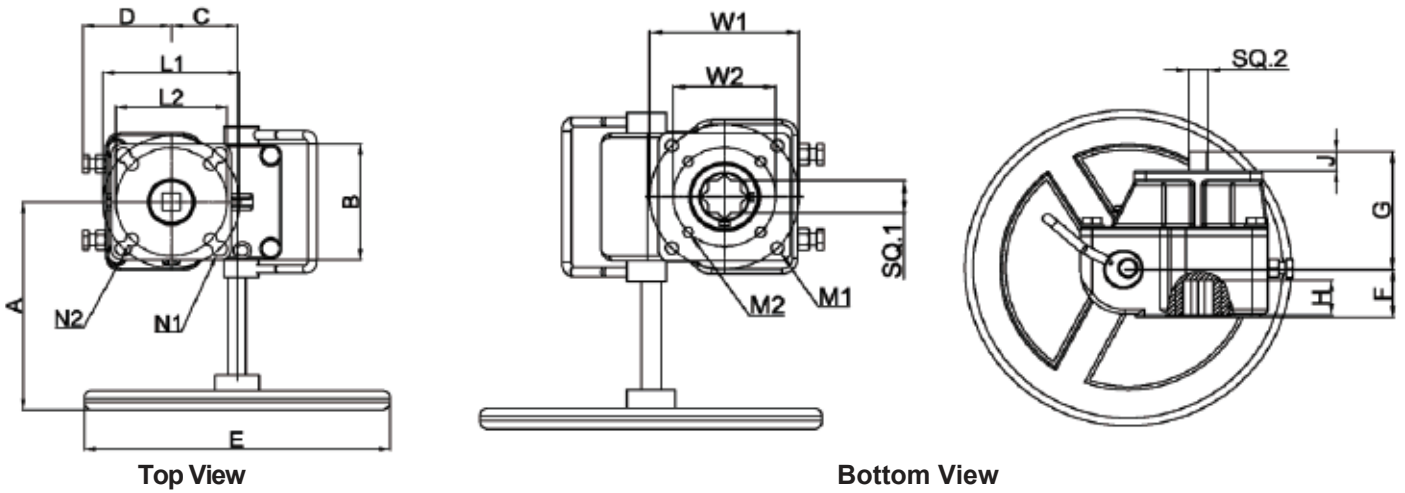

VTH Series Declutchable Manual Gear Override Dimension Table

Model	VTH-S1	VTH-S2	VTH-S3	VTH-S4		VTH-S5		VTH-S6	VTH-S7		
A	140	170	210	260		300		300	400		
B	70	95	115	130		160		160	235		
C	50	55	82	85		120		140	160		
D	60	65	90	100		120		140	160		
E	Φ 180	Φ 200	Φ 280	Φ 300		Φ 400		Φ 500	Φ 600		
F	40	40	40	60		60		75	80		
G	80	90	110	150		175		180	180		
H	12	16	19	25	30	30	40	40	50	50	50
J	12	15	19	25		30	40	40		50	50
M1	M8X4		M10X4	M10X4		M12X4	M16X4	M16X4	M20X4	M20X4	M20X4
M2	M6X4		M8X4	M8X4		M10X4	M10X4	...	M12X4
W1	70	102	102	125	140	14	165	165	165		
W2	50	70	70	102	102	...	125		
SQ. 1	11	14	17	22	27	27	36	36	46	46	46
N1	Φ 10X4		Φ 12X4	Φ 14X4		Φ 18X4		Φ 22X4		Φ 22X4	Φ 22X4
N2	Φ 8X4		Φ 10X4	Φ 12X4		Φ 14X4		Φ 18X4	
L1	70	102	125	140		165		165	165		
L2	50	70	102	125		140			
SQ. 2	11	14	17	22	27	27	36	36	46	46	46

Operation Instruction and Precaution

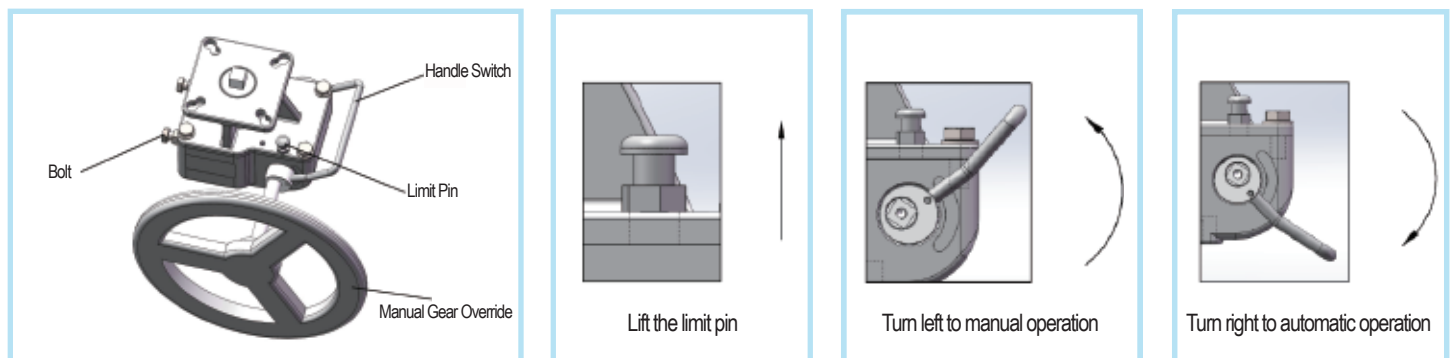

Operation Instruction and Precaution



Manual Operation: Lift the limit pin and rotate the handle. Rotate the handle to upper left to manual limit position and make sure it arrives. Worm gear and vortex rod occlude. Open and close the valve by rotating the hand wheel.

Automatic Operation: Lift the limit pin and rotate the handle. Rotate the handle to lower right to automatic limit position and make sure it arrives. Worm gear and vortex rod detach. It reaches idling condition through rotating the hand wheel.

Notice: Jamming condition may occur when switch the hand wheel to up or down caused by occluding of turbine and vortex rod and can be eliminated by gently shaking the manual gear override. Make sure that turn off air supply to actuator before manual/automatic switching operation.

Selection Method

Model	Flange Connecting to Actuator	Top Shaft	Flange Connecting to Valve	Bottom Shaft	Housing Color	Hard Wheel Color
VTH-S1	F05/07	11	F07/10	11	Standard ■ 9004 Optional Housing Color ■ 7046 ■ 5021 ■ 3020 ■ 6002 ■ 5015	RAL3 00 3
		14		14		
VTH-S2	F07/10	17	F07/10	17		
VTH-S3	F10/12	22	F10/12	22		
		27		27		
VTH-S4	F12/14	27	F10/14	27		
		36		36		
VTH-S5	F14/16	36	F14	36		
		46		46		
VTH-S6	F16	46	F16	46		
VTH-S7	F16	46	F16	46		

Option List - VTH Series Gear Override & VT Series Actuator

Model	Spring Return	Double Acting	Remarks
VTH-S1	VT050S-75S	VT050D-75D	All in recommended configuration of 5bar air pressure and 8 spring cartridges. Customized configuration is also available.
VTH-S2	VT0805S、95S	VT085D-110D	
VTH-S3	VT110S-140S	VT125D、140D	
VTH-S4	VT160S、190S	VT160D、190D	
VTH-S5	VT210S	VT210D	
VTH-S6	VT240S、VT270 S	VT240D、VT270D	
VTH-S7	VT300S	VT300D	

Notice

Pressure-temperature ratings and other performance data published in this catalog have been developed from our design calculation, in-house testing, field reports provided by our customers and/or published official standards or specifications. They are good only to cover typical applications as a general guideline to users of VTORK products introduced in this catalog. For any specific application, users are kindly requested to contact VTORK for technical advice, or to carry out their own study and evaluation for proving suitability of these products to such an application. Failure to follow this request could result in property damage and/or personal injury, for which we shall not be liable. While this catalog has been compiled with the utmost care, we assume no responsibility for errors, impropriety or inadequacy. Any information provided in this catalog is subject to from-time-to-time change without notice for error rectification, product discontinuation, design modification, new product introduction or any other cause that VTORK considers necessary. This edition cancels all previous issues.

The final interpretation right of this sample belongs to VTORK Technology(Wuxi) Co.,Ltd.



No.55 Lianhe Road, Hudai Industrial Park, Binhu District, Wuxi, Jiangsu Province, China
Tel: 0510-85581533 Fax: 0510-85581532 E-mail: info@vtork.cn Website: www.vtork.cn